

Hand Chain Hoists

OzBlok have been a leader in the development and manufacture of quality, reliable chain hoists in the Australian market for over 25 years.

We are proud to announce the addition to our range with these large lift models in 10, 20, 30 and 50 tonne capacities.

With their advanced design and performance these new hoists have applications in heavy engineering, construction, marine, offshore exploration and mining industries.

Each hoist is factory overload tested and comes with test certificate and operating instruction manual.

Available in special lift heights or with optional Overload Protection.

Full technical support and on-site service always available.

10 tonne (WLL)

Product Code: SOCB10

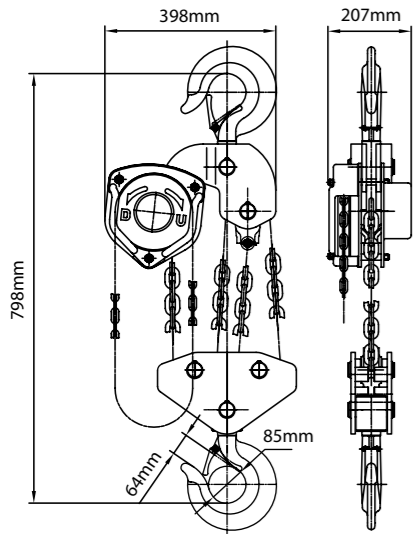

Working Load Limit (WLL)	10 t
Standard Lift	3m
Falls of Chain	4
Hand Effort to Lift WLL	39kg
Net Weight	68kg
Load Chain Diameter	10mm



20 tonne (WLL)

Product Code: SOCB20

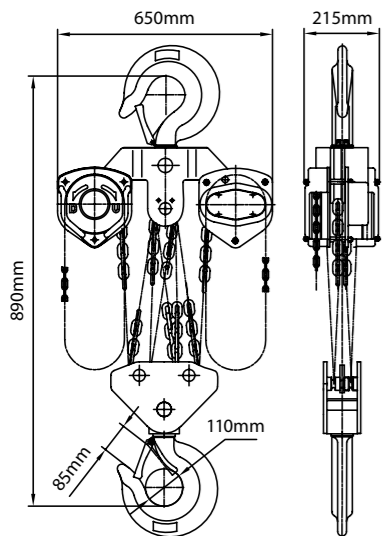

Working Load Limit (WLL)	20 t
Standard Lift	3m
Falls of Chain	8
Hand Effort to Lift WLL	42kg x 2
Net Weight	193kg
Load Chain Diameter	10mm



50 tonne (WLL)

Product Code: SOCB50

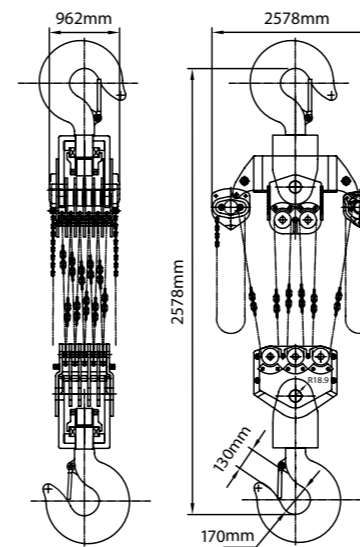

Working Load Limit (WLL)	50 t
Standard Lift	3m
Falls of Chain	22
Hand Effort to Lift WLL	42kg x 2
Net Weight	1092kg
Load Chain Diameter	10mm



30 tonne (WLL)

Product Code: SOCB30

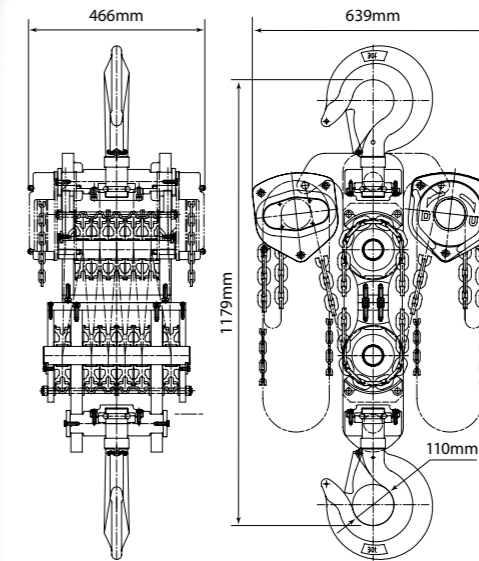

Working Load Limit (WLL)	30 t
Standard Lift	3m
Falls of Chain	12
Hand Effort to Lift WLL	42kg x 2
Net Weight	225kg
Load Chain Diameter	10mm

Complies to AS/NZS 1418.2

ALL HOISTS AVAILABLE WITH OPTIONAL OVERLOAD PROTECTION



FEATURES:

- Strong robust construction
- Super strength Grade 80 load chain.
- Fully machined lift wheel.
- Minimum effort to raise maximum load.
- Cast steel safety latches.
- Lower hook complete with thrust race.
- Fully enclosed gear train.
- Weather protected automatic Weston brake with unique Twin pawls.
- Galvanised hand chain as standard.
- Powder coated paint protection.
- Stainless Steel ID labels.
- Replacement parts always available.

OzBlok

HEAVYWEIGHT CHAMPIONS

Geared Girder Trolleys

OzBlok now offer Geared Girder Trolleys in these large capacities for use with Hand Chain Hoists and other applications.

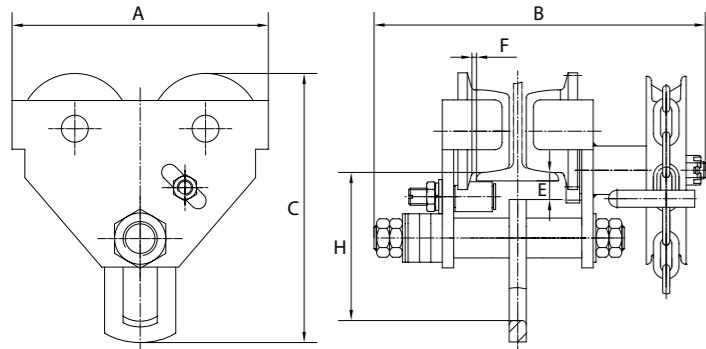

10 tonne

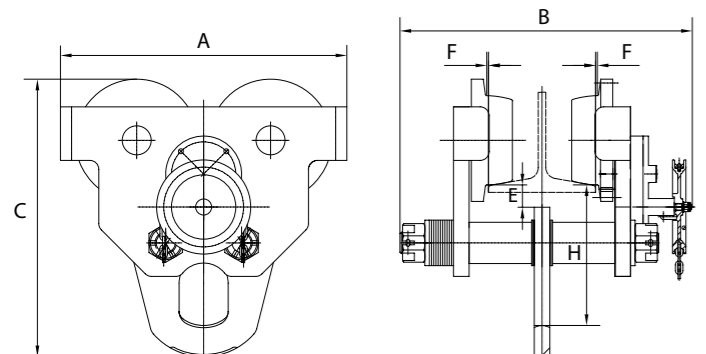

20 & 30 tonne

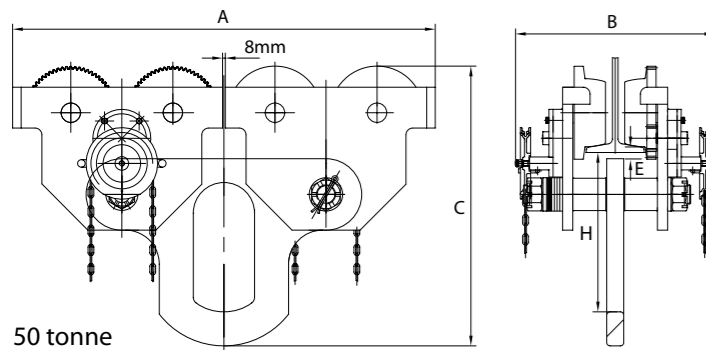

50 tonne

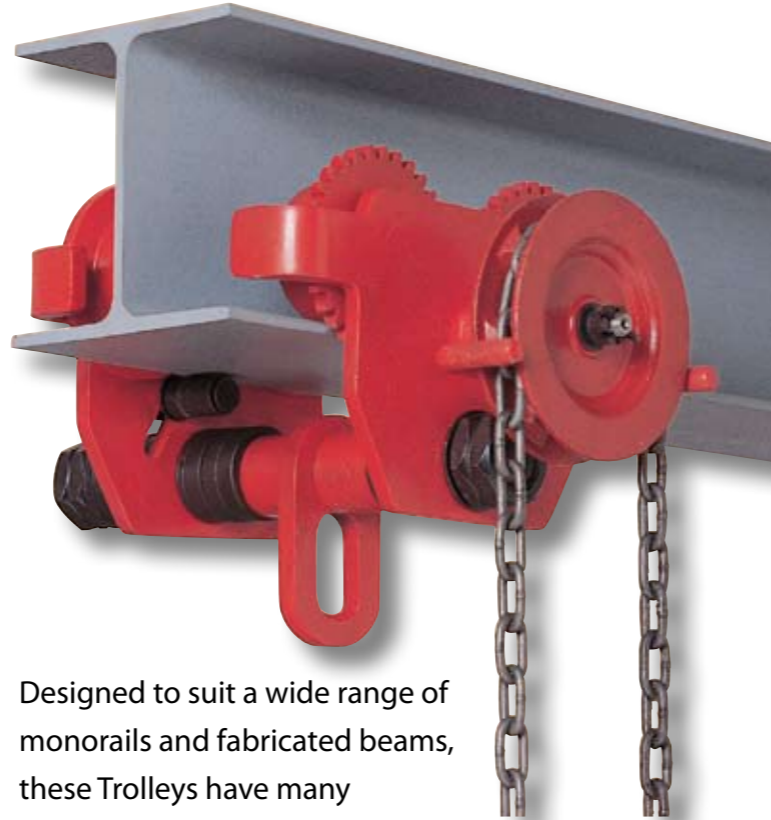

Designed to suit a wide range of monorails and fabricated beams, these Trolleys have many applications in the mining, oil & gas, heavy construction and marine industries.

Complies with AS/NZS 1418.2

FEATURES:

- Strong rugged construction.
- Super quick adjustment to any beam width within range.
- Powder coated paint finish.
- Precision ball bearing trolley wheels with machined tread for smooth operation.



DISTRIBUTED BY:

Product Code	OGT10	OGT20	OGT30	OGT50
Rated Capacity	10 t	20 t	30 t	50 t
Standard Adj. Beam Width* mm	125-210	210-330	**	**
Clearance Dimensions mm	A	455	642	1242
	B	487.5	647	655
	C	490	622	622
	E	35	55	50
	F	4.5	4.5	4.5
	H	275.5	315	312
Min. Radius Curve	m	2.5	4.5	6.0
Net Weight	kg	103	256	577

* Other widths available on request

** Manufactured to customer's requirements

Specifications and dimensions subject to change without notice. © Copyright 02/09

Introducing our new heavyweight champions.



OzBlok

Hand Chain Hoists & Geared Girder Trolleys

Available in capacities of 10, 20, 30 & 50 tonnes